

ION EXCHANGE
INDIA LTD
Total Water Management



canal



From the house of
ZERO B

CONGRATULATIONS!

Dear Customer,

You are now the proud owner of "Softener", India's first Point Of Use (POU) Water Softener from the house of ZeroB [Consumer Products Division of Ion Exchange (India) Limited].

We thank you for giving us the OPPORTUNITY TO SERVE YOU. We are committed to provide you the same level of satisfaction which thousands of our valued customers have enjoyed in the past.

We are the pioneers of water treatment technology in India. Over the last four decades, our efforts have been directed to combat different types of contaminants present in water.

In our endeavor to establish a closer relationship with you, we have created a "Water Care Team". The Water Care Man of this team is a specialist in water treatment. Do not hesitate to call upon his services whenever required.

Thank you once again for giving us this opportunity to serve you.

"Drink to your Health. Safe Water. Healthy life."

With best wishes,

From -

Ion Exchange (I) Ltd.

Consumer Products Division,

ION House, 1st Floor, Plot No. 2, Sector 18, Vashi

Navi Mumbai - 400 705. Tel.: 022 - 27888831/32/33/34

Fax : 022 - 27889839.

C O N T E N T S

1.	Softener	3
2.	Where can the Softener be used?	4
3.	Product Specification	5
4.	Installation of Softener	6
5.	How to Install Softener	7
6.	Plumbing Connections	8
7.	How to use Softener	9
8.	Service at your Doorstep	12
9.	Warranty Cards	13
10.	Service Coupons	15
11.	Other ZeroB Products	21
12.	Regional/ State Offices	23
13.	AMC/ACMC Contract	24

SOFTENIZER

Softener is a sleek wall mounted model that is designed to reduce the Calcium and Magnesium ions (hardness) from water thus making water soft. This Softener helps to increase life & efficiency of costly appliances, decrease consumption of gas & help food taste better, decrease detergent consumption & increase washing effectiveness.

The Softener has the convenience of a knob for selecting soft water output and recharging the softener.

How it works?

The unit consists of a tank containing Ion Exchange Resin Media, which removes hardness from water to tolerable level. When the hard water passes through this Sodium rich Ion Exchange Resin, the media exchanges minerals that cause hardness like Calcium (Ca) and Magnesium (Mg) for Sodium. This results in the softness of water that comes out from the outlet. After continuous usage, the resin gets saturated with minerals causing hardness i.e. Ca. and Mg. Then this Ion Exchange Resin has to be regenerated or recharged using common salt. The ion exchange process requires salt to be added periodically to the Softener unit, a step called "Recharging". In the recharging cycle, salt water is passed through the resin bed. Sodium ions from the salt water replace Ca and Mg ions which are attached to the resin. Once again the resin becomes rich in Sodium which is again ready for softening.

Features

- Soft water available at the twist of a knob
- Easy to recharge (for soft water)
- Low pressure operation
- No replacement of media
- Sleek wall mount design, easy to fit

WHERE CAN THE SOFTENIZER BE USED?

- Softener can be attached to geysers, resulting in their increased life and also less power consumption
- It can be used to prevent the choking of taps and fittings that is caused due to hardness & scale depositions
- Softener can be used as an attachment to the washing machine
- Softener can be connected to a dish washer
- It can be connected to a kitchen loft tank for washing vessels
- It can be used as pre-treatment to water purifiers like UV & RO

BENEFITS OF SOFTENIZER

- Clothes are softer, cleaner, brighter and last longer
- Prevents rusting and scaling in appliances such as geysers, washing machines and dishwashers and greatly extends the life of immersion rods and hot water heaters.
- Increases the life of expensive fittings
- Reduces hair loss
- Moisturizes skin
- Clothes & dishes are cleaner, with less soap application
- Less consumption of energy by electrical appliances
- Does not require electricity for operation

PRODUCT SPECIFICATION

Product Specification of Softener

Flow rate of treated water	8 -10 Ltrs. / min
Maximum allowable hardness in the raw water as CaCO	500 ppm
Maximum allowable hardness (outlet) of treated water as CaCO,	< 50 ppm
Soft water output	250 Ltrs. (at hardness of 500 ppm) 500 Ltrs. (at hardness of 250 ppm)
Recharging time	30 minutes
Mode of recharging	Manual
Recharging material	NaCl / Khadi salt / Common salt
Minimum-Maximum inlet pressure	0.5-4 kg /cm
Inlet-Outlet port size	1/2" BSP
Dimensions	550mm(height) x 150mm(diameter)
Weight	6.85 kg

Note

- The Softener only removes excess hardness from water but it does not disinfect or purify the water
- Inlet water should be free from oil, grease and excessive turbidity

SOFTENIZER COMPONENTS

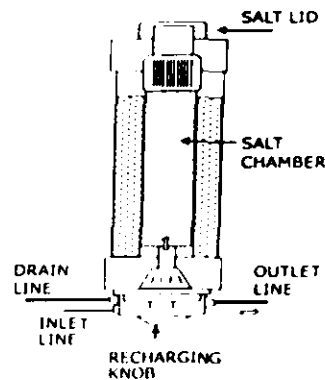

INSTALLATION OF SOFTENIZER

WHERE TO INSTALL THE SOFTENIZER

Softener has to be installed, such that the salt filling cap of the Softener is not more than 4 - 4.5 feet from the ground (check customer convenience for tightening the lid).

TYPICAL INSTALLATION SHOWN

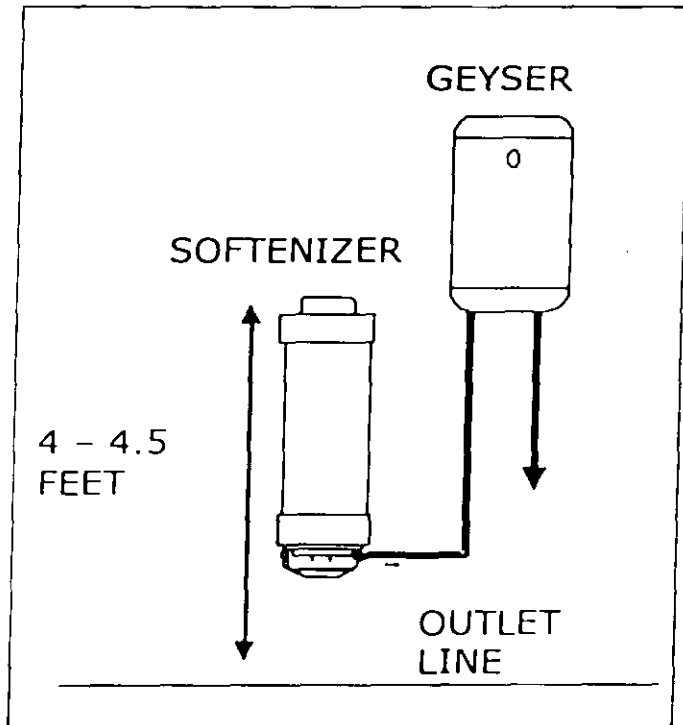

HOW TO INSTALL SOFTENIZER

- Use the key hole template to fix screws on the wall
- Fix a pair of screws to hold the upper ring of the product (only for support)
- Fix another pair of screws for the lower ring (for load bearing)
- Mount the product on the respective screws. Ensure that the weight of the unit falls on the lower mounting plate

MOUNTING THE SOFTENIZER

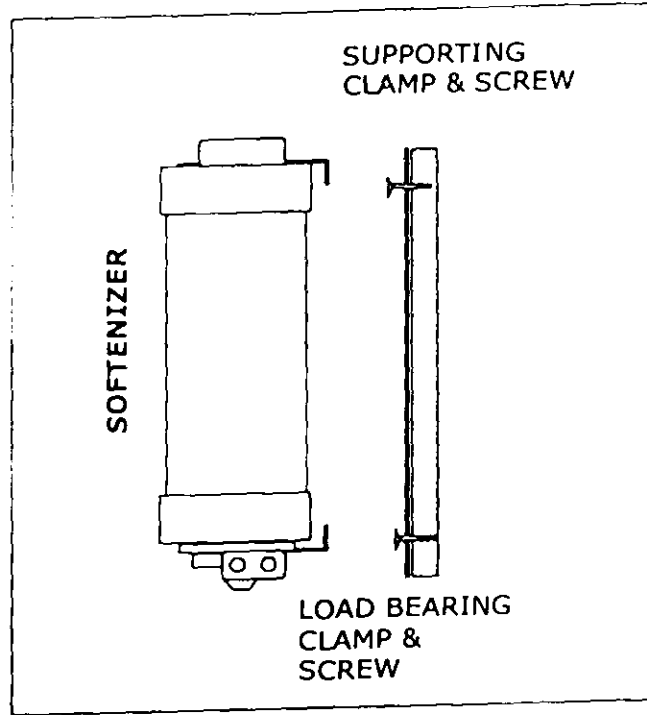

PLUMBING CONNECTIONS

- Fix a flow control valve at the inlet line of the Softener
- Connect the raw water line to the inlet port of the Softener
- Connect the outlet line to the geyser / washing machine etc
- Terminate drain tube to the nearby drainage line

SOFTENIZER PLUMBING

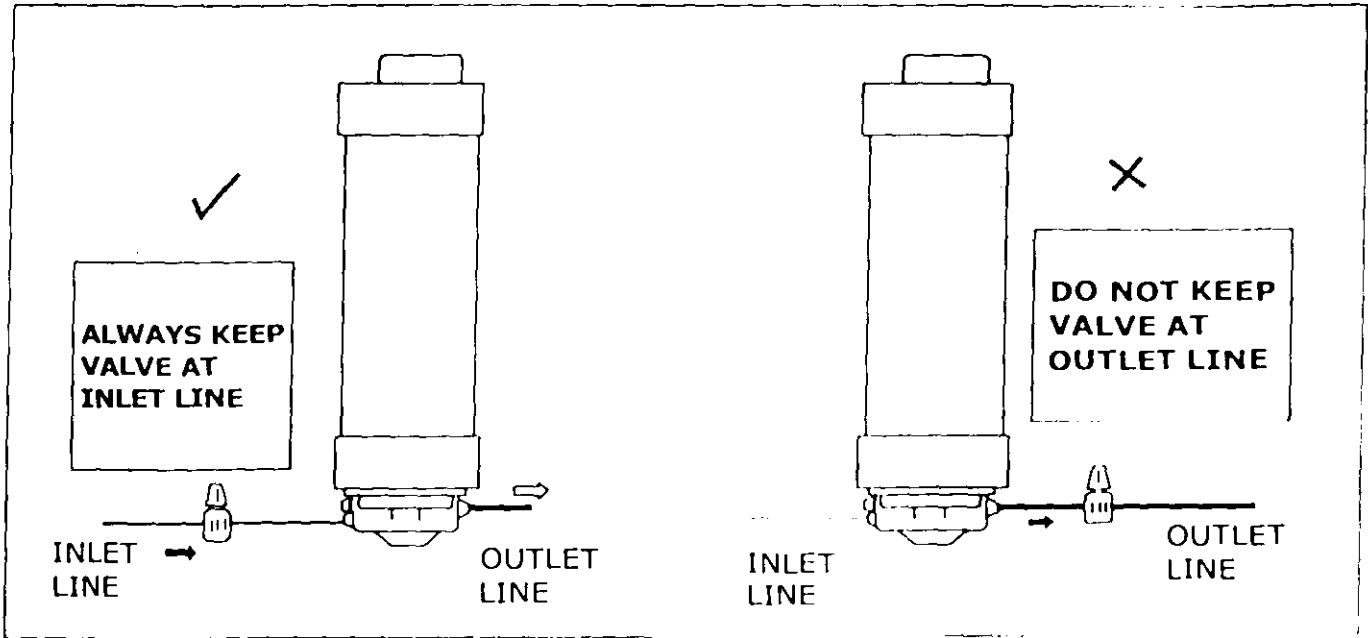

HOW TO USE THE SOFTENIZER

The Softener unit is operated in two modes:

Soft water mode

In softening mode, the knob should be in a straight position. Open the inlet valve in such a way that the output flow is around 8-10 Ltr./min.

Check the soft water quality using a simple soap test.

Recharging mode

Once the capacity of the Softener is over, it will start giving hard water. The recharging of the Softener can be planned on the basis of water consumption.

To recharge the unit:

1. Close the inlet line
2. Turn the knob fully in clock wise direction
3. Open the lid of the Softener. Fill the salt chamber with common salt up to the brim (approximate 500 gms).
4. Close the lid of the Softener
5. Open the inlet line
6. Salty water will start coming out from the drain
7. Wait for 30 minutes
8. After 30 minutes, again turn the knob in a straight position
9. Now Softener is ready to deliver the soft water

HOW TO USE SOFTENIZER

SOFT WATER MODE

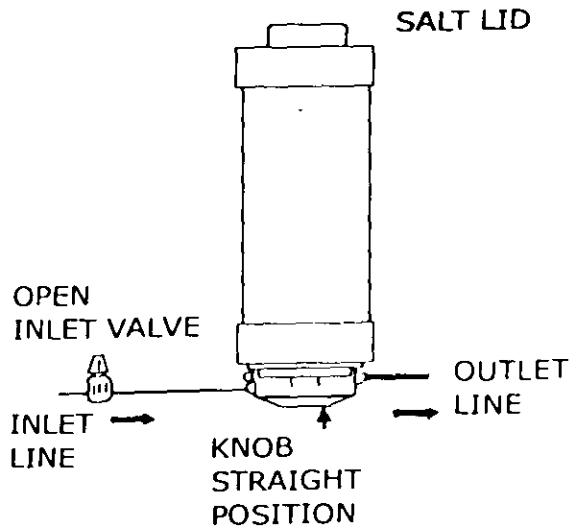

CHARGING / SALT FILLING

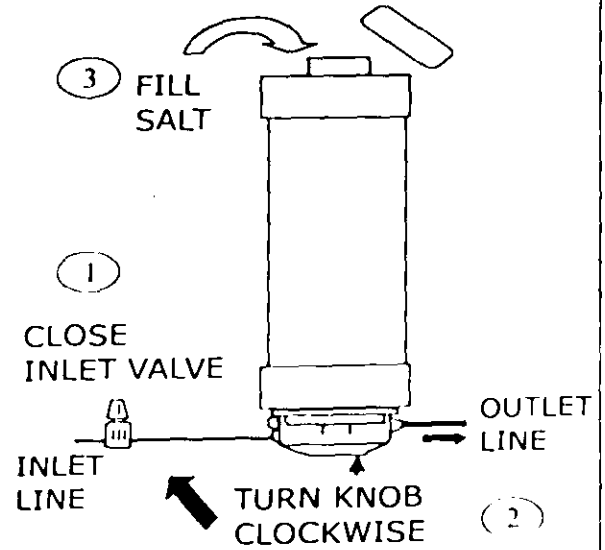

READY FOR CHARGING

4

CLOSE
SALT LID

CLOSED
INLET VALVE

INLET
LINE

OUTLET
LINE

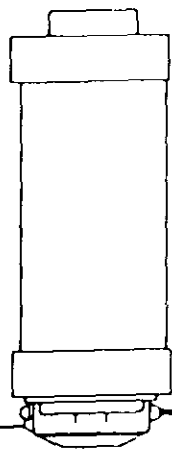

CHARGING FOR 30 MINS.

DRAIN
LINE

OPEN
INLET VALVE

5

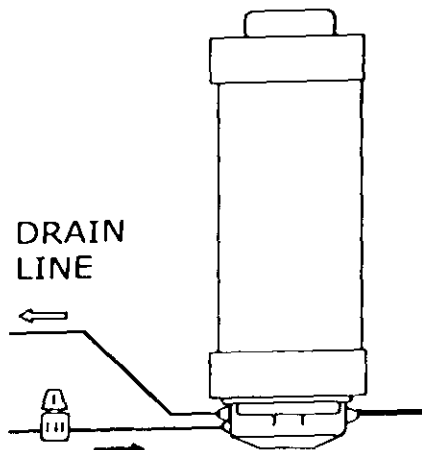

SERVICE AT YOUR DOORSTEPS

The Company offers you One Year Warranty for your Zero B Softener. This includes three free visits by our Service Engineer.

After expiry of Warranty you can avail the option of entering into Annual Maintenance Contract with us. For details do remember to ask for your copy of the Contract from the company before the Warranty Period gets over.

For free servicing during the Warranty Period call our local office.

ION EXCHANGE (INDIA) LTD., CONSUMER PRODUCTS DIVISION, Ion House, Plot No.2, Sector 18, Vashi, Navi Mumbai - 400 705, Tel.: 27888831/32/33

BRANCH/DSA OFFICES: Delhi: 011-26173318, 011-26175891, 0124-4035944/946/947, 0120-2442231/32; Ludhiana: 9317745222, 9217882917; Amritsar: 9814261750, 9876161750, 9814094087; Jalandhar: 9815100105; Batala: 9814046949, 9814077788, Hoshiyarpur: 9872363860, 9814270033. Moga: 9815477074; Samalsar: 9357744150; Phagwara: 9316827245; Ambala: 9416005220; Faridkot: 9872026957; Ferozpur: 9815626957; Muktsar: 9356872177; Khanna: 01628-234003; Mandigobindgarh: 9814242150; Chandigarh: 9417495847; Bangalore: 080-41161281, 25274395, 41244338/224, 26787950/48/46, Mumbai: 022-24939523/20, Allahabad: 0532-2600556, Ahmedabad: 079-26924847; Baroda: 0265-2386354; Jaipur: 9314663423, 9829053423; Pune: 020-27146109, 27197513; Kolkata: 033-23213873/79; Howrah: 25211878 / 25210165; Guwahati: 0361-2660139/230; Siliguri: 0353-6521935

WARRANTY CARD

(To be filled in by the sales representative and retained by the customer for reference.)

Unit Serial No.: _____

Invoice No. _____ Dated: _____

Date of Expiry of Warranty: _____

Customer's Name and Address: _____

Tel.No.(Res.) _____ (Off.) _____ Fax No: _____

E-mail: _____

Customer's Signature: _____ (I accept the terms and conditions of warranty.)

Company's Stamp & Signature

(To be given back to the company)

Date: _____

JUST FILL IN THIS WARRANTY CARD AND GIVE IT TO US WITHIN 7 DAYS FROM THE DATE OF PURCHASE OF THIS PRODUCT

Unit Serial No.: _____

Date of Purchase: _____

(Please help us to understand you better. Just fill in the details or tick the appropriate boxes, wherever provided. Thank you!)

My Name: _____

My Age: 18-25 25-30 30+ My Occupation: _____

My approx. monthly household income (in Rs.) Above 10000 Above 20000 Above 30000

I own a Water Purifier, Yes No If Yes, specify which Brand: _____

My Residential Address: _____

City: _____ State: _____ Pin Code: _____

My Tel. No. (Res.): _____ (Off.): _____ Fax No: _____

My Signature: _____ (I accept the terms and conditions of warranty.)

Company's Stamp & Signature



WARRANTY CARD

Please preserve this Warranty Card and ensure that it is duly stamped and signed by the company official. Ion Exchange Softener (therein referred to as the product) is warranted throughout India only by Ion Exchange (I) Limited (herein referred to as the company) as per the conditions printed.

TERMS & CONDITIONS OF WARRANTY

- The product is warranted against any manufacturing defects arising out of any faulty or defective material or workmanship for a period of 12 months from the date of invoice.
- The company's responsibility under this warranty will confine to the first purchaser only, and will not apply or extend to any subsequent sale of the product by the customer.
- The company's liability under this warranty shall remain valid only if, the product is duly installed by the company at the address specified in the invoice or where the installation is at a place other than specified in the invoice, such installation is undertaken only with the consent of the company.
- The customer shall notify the company in writing promptly, of any defects noticed and give the company adequate opportunity to inspect, test and remedy them. For this the customer will deposit the product if so required by the company, with the company office/service centre along with the warranty and proof of purchase.
- The company's responsibility will be either to repair the defective components or exclude defects occurring because of abuse or faulty maintenance, repairs to goods or parts by others. The consumable components are not covered under this warranty.
- The company will be entitled to retain any defective part replaced under warranty.
- The consumer will have no claim under this warranty in respect of death, injury to any person or loss/damage to any property caused as a result of equipment failure, breakdown or accident on utilisation of goods not in accordance with the instructions in this user's manual or any other circumstances beyond the control of the company. Any dispute arising out of this warranty will be settled in the courts at Mumbai only.

BUSINESS REPLY CARD

To,
Ion Exchange (I) Ltd
Consumer Products Division,
ION House, 1st Floor, Plot No. 2, Sector 18,
Vashi, Navi Mumbai-400 705.
Tel.: 027888831/32/33/34
Fax: 022 - 27889839.

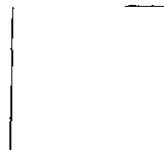

1st SERVICE COUPON

Model Name: _____

Unit Serial No.: _____

Customer Name: _____

Installation Date: _____

Service Date: _____

Serviced By: _____

Customer Signature: _____

- After the machine is serviced sign the coupon, and give it to 'Water Care' Service Engineer
- Valid only for a period of one year from the date of purchase
- Non-transferable and non-extendable
- Cannot be encashed
- Ensure that the machine is serviced to your satisfaction before handing the signed coupon to 'Water Care' Service Engineer.

2nd SERVICE COUPON

Model Name: _____

Unit Serial No.: _____

Customer Name: _____

Installation Date: _____

Service Date: _____

Serviced By: _____

Customer Signature: _____

- After the machine is serviced sign the coupon, and give it to 'Water Care' Service Engineer
- Valid only for a period of one year from the date of purchase
- Non-transferable and non-extendable
- Cannot be encashed
- Ensure that the machine is serviced to your satisfaction before handing the signed coupon to 'Water Care' Service Engineer.

3rd SERVICE COUPON

Model Name: _____

Unit Serial No.: _____

Customer Name: _____

Installation Date: _____

Service Date: _____

Serviced By: _____

Customer Signature: _____

- After the machine is serviced sign the coupon, and give it to 'Water Care' Service Engineer
- Valid only for a period of one year from the date of purchase
- Non-transferable and non-extendable
- Cannot be encashed
- Ensure that the machine is serviced to your satisfaction before handing the signed coupon to 'Water Care' Service Engineer.

OTHER ZERO B PRODUCTS

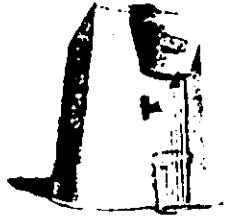

Zero B Pristine

Zero B Pristine comes in a futuristically designed compact pack to give you pure, clean, healthy and fresh tasting water.



Softener (High-capacity)

India's first domestic water softener, softens water as per WHO prescribed limits. Hard water decreases life and efficiency of costly appliances, increases consumption of gas, alters taste of food, detergent consumption and reduces washing effectiveness. Also available in the capacity of 1000 Ltr.



Zero B Autosoft

India's first truly automatic water softener for homes with an output of 2000 Ltr. per hour.



Zero B RO

Wall Mount Reverse Osmosis water purifier comes with a unique seven stage purification system with 3 stage pre-filters. It is India's first Reverse Osmosis purifier with detachable tank for cleaning and serving. This purifier consumes low space, provides great taste with all the features of most advanced RO purifier.



D - Ferrous (High-capacity)

India's first domestic iron remover, removes Iron from water as per WHO prescribed limits. Excessive Iron in water causes corrosion of costly appliances, causes tissue damage, constipation and loss of appetite, increases maintenance power and fuel consumption of washing machines, water heaters, dish washers, steam irons and car radiators.



Zero B Water Vending Station

Water vending machine is installed to retail potable drinking water conforming to ISI standards. Water passes through multi-stage purification process and ozonation, dispenses water in units of 200 ml, 1 Ltr. and 5 Ltr. in chilled and non chilled options.



Zero B Pristine Split RO

This under the counter Reverse Osmosis Unit, removes sediment, harmful bacteria, viruses and chemical impurities from water.



Zero B Ultimate

It is a table top Stage 7 Reverse Osmosis System which removes sediment, harmful bacteria, viruses and chemical impurities from water.

REGIONAL / STATE OFFICES

North	<p>Ion Exchange (I) Ltd C-17 Sector - 2 (Behind Nirula Ltd Noida - 201301 Tel - 9891565055</p>	<p>Ion Exchange (I) Ltd 1st Floor Shri Hira Plaza Commercial Complex By Pass Rd. Agra - 282005 Tel - 0562-2852687 2854081</p>	<p>Ion Exchange (I) Ltd 1-B Mohammadpur, Bhikaji Cama Palace New Delhi - 110066 Tel - 9310910890</p>	<p>Ion Exchange (I) Ltd SCO-26, 1st Floor, Main Market, Sec 31 Gurgaon - 122001 Tel - 9350501825</p>	<p>Ion Exchange (I) Ltd. C/O Fairdeal Technologies Ltd. 205-206, Arihant Tower Opp Telephone Exchange Sanganeri Gate, Agra Road. Jaipur - 302003 Tel - 0141-2611265</p>	<p>Ion Exchange (I) Ltd Saran Chamber Flat No. 1&2 6th Floor, Park Road Lucknow - 226001 Tel - 0522-3292901</p>
East	<p>Ion Exchange (I) Ltd New Alipor Market Complex Block - 11 Phase-1, 5th floor Kolkata - 700053 Tel - 033-23213579</p>					
West	<p>Ion Exchange (I) Ltd Ion House, Plot No 2 Sector 18, Vashi Nav Mumbai - 400705 Tel - 27888831 to 34</p>	<p>Ion Exchange (I) Ltd Trecion House, Dr E Moses Road Mahalaxmi Mumbai - 400011 Tel - 022-24939523</p>	<p>Ion Exchange (I) Ltd Neeta Tower, Opp Sandvik Asia, 2nd Floor, Mumbai Pune Road Dapodi Pune - 411012 Tel - 9520-27147513/6063</p>	<p>Ion Exchange (I) Ltd 103, Manas Complex Near Jodhapur Cross Rd. Satellite Road Ahmedabad - 380015 Tel - 079-26924846/47/ 65222871</p>	<p>Ion Exchange (I) Ltd Nirali Apartment (Near Telegraph Office) Ellora Park, Ground Floor Baroda - 390007 Tel - 0265-2386354</p>	<p>Ion Exchange (I) Ltd. Plot No. L 48 & L 49, Verna Electronics City, Phase II, Verna Salcette, Goa - 403722 Tel - 0832-2783159</p>
South	<p>Ion Exchange (I) Ltd Plot No. 3 Bapu bagh, P.G. Road Secundrabad-500003 Andhra Pradesh Tel - 040-66484667</p>	<p>Ion Exchange (I) Ltd 10, 1st Floor, Manjunath Plaza Opp Poomima Nursing Home Dinnur Main Road, RT Nagar Bangalore - 560032 Tel - 080-41244338/224</p>	<p>Ion Exchange (I) Ltd. CPD Direct Sales 682, 1st Main Road (Syndicate Bank Road) 1st stage Indira Nagar Bangalore - 560038 Tel - 080-41161281</p>	<p>Ion Exchange (I) Ltd. 6-3-347/22 Riviera Apt. Plot No. 134, 4th Floor Dwarkapuri Colony Punjagutta, Hydrabad - 500482 Tel - 040-23321630/ 23328389</p>	<p>Ion Exchange (I) Ltd. 23D: C Block 21 Mandiraapt Pioneer Homes, B.N Reddy Road, T. Nagar, Chennai - 600017 Tel - 044-28150973/4974</p>	<p>Ion Exchange (I) Ltd. Sneha Apts. No. AC65 Ground Floor, Shanti Colony, Anna Nagar, Chennai - 600040 Tel - 044-26285204/ 42026400</p>

“Zero B Service”

Always trust Genuine Ion Exchange (India) Ltd. spare parts for smooth functioning and longer life of your product.

Zero B Service: After completion of 1st year of warranty, we offer you two service options namely APMC and AMC.

APMC

Annual Comprehensive Maintenance Contract (APMC), a unique service option takes care of service and spares/consumables replacements (if any) during the contract period.*

AMC

Annual Maintenance Contract (AMC), entitles your product for free servicing during the contractual period. The replacement of spares/consumables is not included in the contract.*

With Annual Contracts ensure:

- Safety with Genuine Ion Exchange parts
- Proper maintenance of product
- Enhanced product life
- Uninterrupted and timely service by qualified company service personnel

For more information contact our regional service centre

Ion Exchange (India) Ltd., is a leader in the business of water treatment and solutions which is so vital to people's lives and the environment. For more than four decades, Ion Exchange (India) Ltd., has pioneered many path-breaking innovations in the field of engineering and marketing to provide a single-stop solutions for industries, homes and the communities. Bearing testimony to this are more than 35,000 water treatment installations worldwide. Our plants have been exported to USA, UK, South East Asia, Japan, Middle East, Far East, as well as neighbouring countries like Bangladesh, Nepal, Mauritius and Sri Lanka.

In the consumer market, under the flagship of the Zero B brand, the company has introduced products catering to every need of the customer. From On-line Water Purifiers to the most advanced Reverse Osmosis Water Purifiers, from drinking water vending machines to bottled packaged water, to name a few, Ion Exchange (India) Ltd. has pioneered virtually every breakthrough in the Indian market fulfilling the company's vision :
"To be the leader in our business which is so vital to people's lives and the environment."

Local Service Center

